

APPENDIX A

Equations in electronics

- (a) In solving quantitative problems, learners should be able to use correctly the following relationships using standard SI units, without them being provided:

voltage = current \times resistance

$$V = IR$$

power = voltage \times current

$$P = VI$$

power = (current)² \times resistance

$$P = I^2 R$$

energy transfer = power \times time

$$E = Pt$$

$$R = R_1 + R_2$$

resistors in series

$$R = \frac{R_1 R_2}{R_1 + R_2}$$

resistors in parallel

- (b) In addition, learners should be able to select correctly from a list and apply the following relationships:

$$V_{\text{OUT}} = \frac{R_2}{R_1 + R_2} V_{\text{IN}}$$

voltage divider

$$P = \frac{V^2}{R}$$

power dissipated in a resistor

$$I = g (V_{\text{D}} - V_{\text{GS}})$$

MOSFET

$$I_{\text{C}} = h_{\text{FE}} I_{\text{B}}$$

current gain of a junction transistor

$$f = \frac{1}{T}$$

frequency, period relationship

$$T = 1.1RC$$

time delay of a monostable

$$f = \frac{1.44}{(R_1 + 2R_2)C}$$

frequency of an astable

$$T_{\text{ON}} = \frac{R_1 + R_2}{2}$$

mark/space ratio of an astable

$$T_{\text{OFF}} = R_2$$

$$G = \frac{V_{\text{OUT}}}{V_{\text{IN}}}$$

amplifier voltage gain

$$G = 1 + \frac{R_{\text{F}}}{R_1}$$

non-inverting op-amp circuit voltage gain

$$G = -\frac{R_{\text{F}}}{R_{\text{IN}}} \left(\frac{V_1}{R_1} + \frac{V_2}{R_2} + \dots \right)$$

inverting op-amp circuit voltage gain

$$V_{\text{OUT}} = -R_{\text{F}} \left(\frac{V_1}{R_1} + \frac{V_2}{R_2} + \dots \right)$$

summing amplifier output voltage

$$\left. \begin{aligned} \overline{A + B} &= \overline{A} \cdot \overline{B} \\ \overline{A \cdot B} &= \overline{A} + \overline{B} \end{aligned} \right\}$$

Boolean identities

APPENDIX B

SI units used in electronics

Learners should recognise, carry out calculations and be able to communicate using:

(a) The following SI units:

ampere (A), second (s), hertz (Hz), joule (J), watt (W), volt (V), ohm (Ω);

(b) The following SI multipliers:

p, n, μ , m, k, M, G, T.

APPENDIX C

Mathematical requirements and exemplification

In order to be able to develop their skills, knowledge and understanding in electronics, learners need to have been taught, and to have acquired competence in the following areas of mathematics indicated in the table below.

The table illustrates where these mathematical skills may be developed and could be assessed. The list of examples is not exhaustive. These skills could be developed in other areas of the specification content.

	Mathematical skill	Exemplification of mathematical skill (assessment is not limited to the examples given below)
1 – arithmetic and numerical computation		
a	Recognise and use expressions in decimal form	Convert between units with different prefixes, e.g. A to mA Identify the correct units for physical properties such as Hz, the unit for frequency
b	Recognise and use expressions in standard form	Use frequencies expressed in standard form such as 2.5×10^7 Hz
c	Use fractions, ratios and percentages	Calculate the fraction of the charge lost from a capacitor in a given time
d	Calculate squares and square roots	Calculate the power rating required for a resistor
2 – handling data		
a	Use an appropriate number of significant figures	Report calculations to an appropriate number of significant figures Understand that calculated results can only be reported to the limits of the least accurate measurement
b	Find arithmetic means	Calculate a mean value for repeated experimental findings
c	Make order of magnitude calculations	Evaluate equations with variables expressed in different orders of magnitude, e.g. $150 \text{ k}\Omega$ and 2.6 mA



	Mathematical skill	Exemplification of mathematical skill (assessment is not limited to the examples given below)
3 – algebra		
a	Understand and use the symbols: =, <, <<, >, >>, ∞, ~	Recognise the significance of the symbols in the expression: $V_{IN} < 0.7 \text{ V}$ the npn transistor is off
b	Change the subject of an equation	Rearrange $P = \frac{V^2}{R}$ to make R the subject
c	Substitute numerical values into algebraic equations using appropriate units for physical quantities	Calculate the frequency of a 555 astable by substituting the values for R_1 , R_2 and C into the equation: $f = \frac{1.44}{(R_1 + 2R_2)C}$
d	Solve simple algebraic equations	Find a capacitor value for a given time delay and resistance in a 555 monostable
e	Use simple Boolean identities	Simplify a logic system
4 – graphs		
a	Translate information between graphical, numerical and algebraic forms	Measure the ripple voltage from output graphs for rectified power supplies
b	Plot two variables from experimental or other data	Plot I-V characteristics of a diode
c	Draw an appropriate trend line onto plotted data	Drawing a trend line for ntc thermistors resistance against temperature
d	Interpret data presented in graphical form	Reading data from an amplifier's voltage gain graph
e	Determine the slope of a graph	Calculate a resistance value from a V-I graph
f	Calculate the rate of change from a graph showing a linear relationship	Calculate the slew rate from a V-t graph
g	Draw and use the slope of a tangent to a curve as a measure of rate of change	Calculate the gain of an amplifier from the transfer characteristic

APPENDIX D

Electronic symbols

Learners should recognise and be able to use the following electronic symbols:

Switch (latching) 	Switch (non-latching) 	Light dependent resistor 	Thermistor
Photodiode 	Microphone 	Variable resistor 	Potentiometer
Resistor 	Capacitor 	Electrolytic capacitor 	Inductor
NPN transistor 	N channel MOSFET 	Diode 	Zener diode
AND gate 	OR gate 	NOT gate 	NAND gate
NOR gate 	Op-amp 	Schmitt inverter 	Ammeter
Voltmeter 	Buzzer 	Speaker 	Light emitting diode
Signal lamp 	Filament lamp 	Heater 	Motor
Relay 	Cell 	Battery 	AC supply

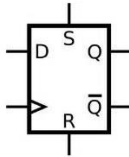
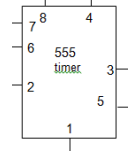
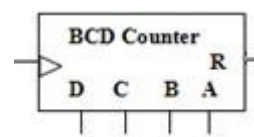
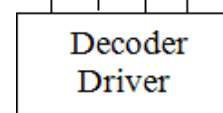
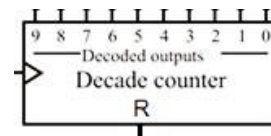
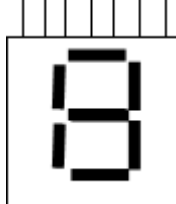
<p>Earth</p> 	<p>Transformer</p> 	<p>D type flip flop</p> 	<p>555 timer</p> 
<p>Binary counter</p> 	<p>Decoder driver</p> <p>A B C D</p>  <p>a b c d e f g</p>	<p>Decade counter</p> 	<p>7 segment display</p> 

Circles can be put on S and R inputs for D types, and on CK and R inputs for counters (or bars over the letters) when inverted.

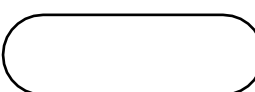
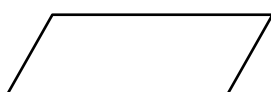
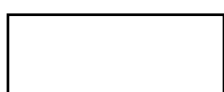
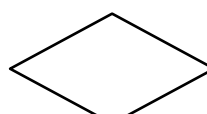
<p>Terminator</p> 	<p>Input/output</p> 	<p>Process</p> 	<p>Decision</p> 
---	---	---	---

